



LOW BOILER FRAME INSTALLATION AND INSTRUCTION MANUAL (2 COLLECTORS)



1. general installation instructions

Before the installation of the solar unit please read all the information and instructions in the present manual.

In accordance with the final user of the unit please consider all the details that will ensure safe and proper installation. Such details are the selection of position, the orientation, the layout of the pipes, the suitable surface etc.

The position must not be shaded during the whole year by trees or other obstacles.

The installation should comply with the local electrical and plumbing regulations.

For optimal efficiency the unit should face South for the North hemisphere and vice versa for the South Hemisphere. In case this is not absolutely possible it can be positioned 30° to the East if DHW demand is before 14:00 or it can be positioned 30° to the West if DHW demand is after 14:00. In both cases the loss of thermal gain will not be greater than 6% annually.

If the unit is to be placed on a roof with inclination angle less than 15° or more than 30° then a special equipment other than the standard support frame must be used. This special equipment is similar to the one used in areas that suffer storms extremely strong wind and hurricanes (Windy Set)

For tilted roof installation it is absolutely essential that the frame should be positioned ensuring that the water tank is exactly over a horizontal post and never between two posts.

If the surface on which the unit will be installed is not compatible with the standard equipment provided then a different equipment should be used.

This equipment should be suggested, chosen and installed by the installer in accordance with the final user.

When the unit is to be installed on a tilted roof the brackets must be tighten down with suitable bolts that ensure a proper and safe installation.

In areas of high snowfall extra care must be shown that the snow is not trapped behind the water tank and that the standard frame is capable withstanding the expected weight of snow.

The same care must apply to areas that suffer heavy storms, extremely strong wind and hurricanes. In such areas use the Windy Set.

Both the pipes of the solar unit and the pipes of cold and hot water to the building must be properly insulated.

Only skilled technicians must perform the filling and connecting of the closed circuit. Before the filling of the closed circuit with thermal fluid the water tank must be completely filled with water.

After the installation of the unit clean-up the surrounding area. Fill the guarantee form and mail it to the manufacturer or the local distributor.

The manufacturer is not responsible in any way for damages caused to the product or others due to wrong installation.

Installation Kit

2 solar thermal collectors



Optional equipment
(not included)

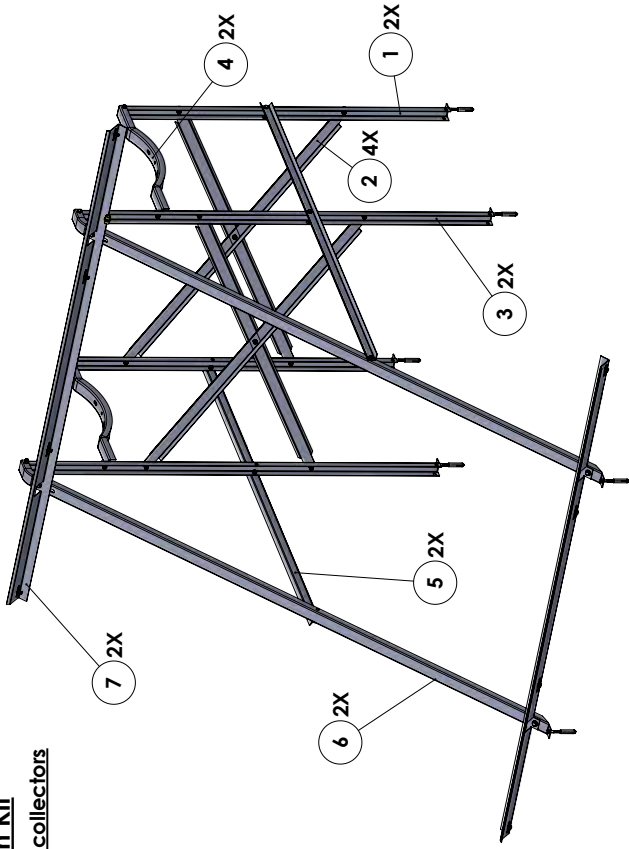

Hexagon head bolt
M8x16mm
26 items



Hexagon head bolt
M8x60mm
4 items



Hexagon nut M8
26 items



Hexagon head wood screws
DIN 571 A4 Ø8x60mm
6 items



Safix Plastic 8mm plug
6 items



Washer M8
18 items



Hexagon head bolt
M8x20mm
6 items

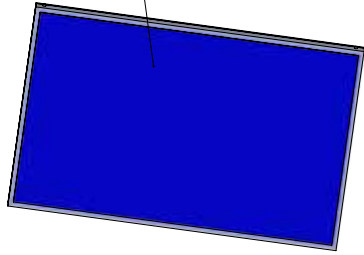
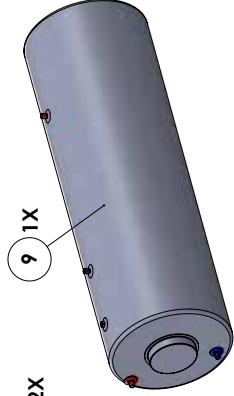

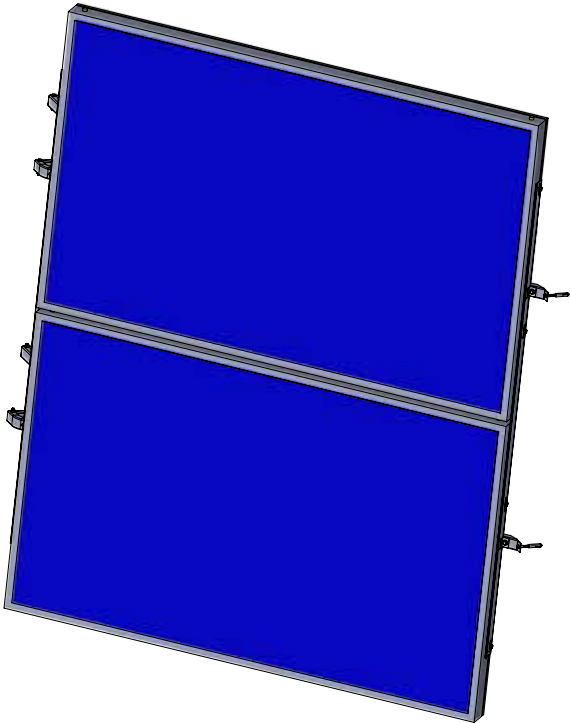
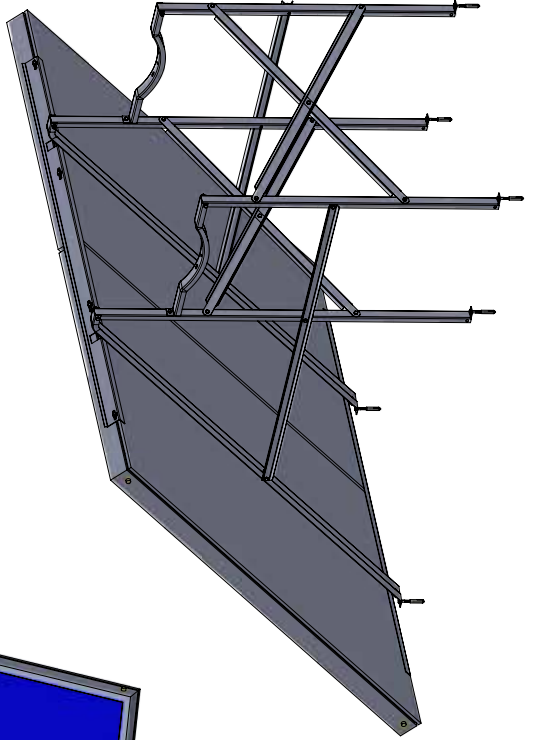

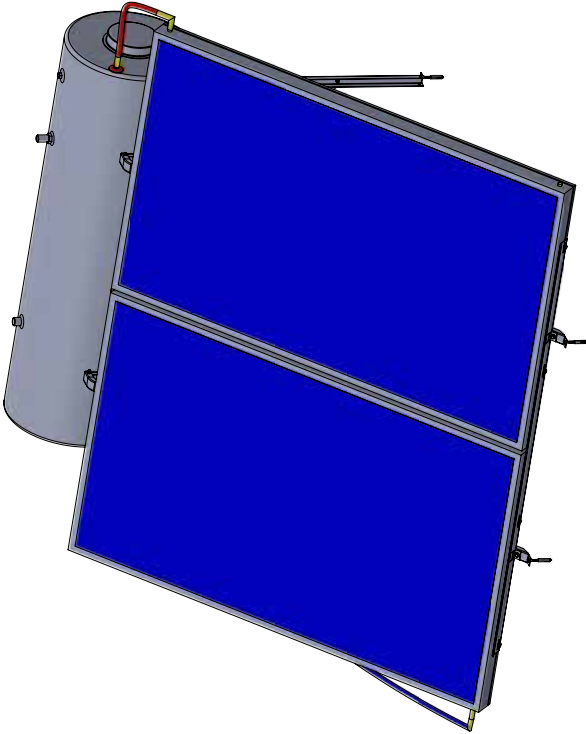
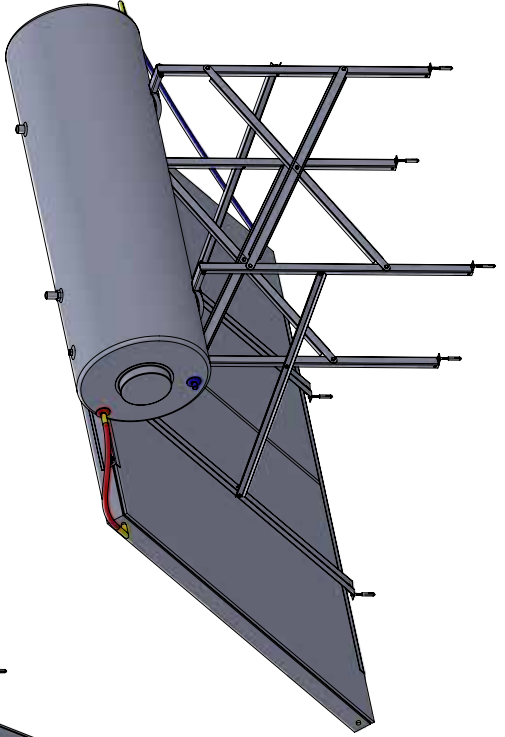

Assembly step 1

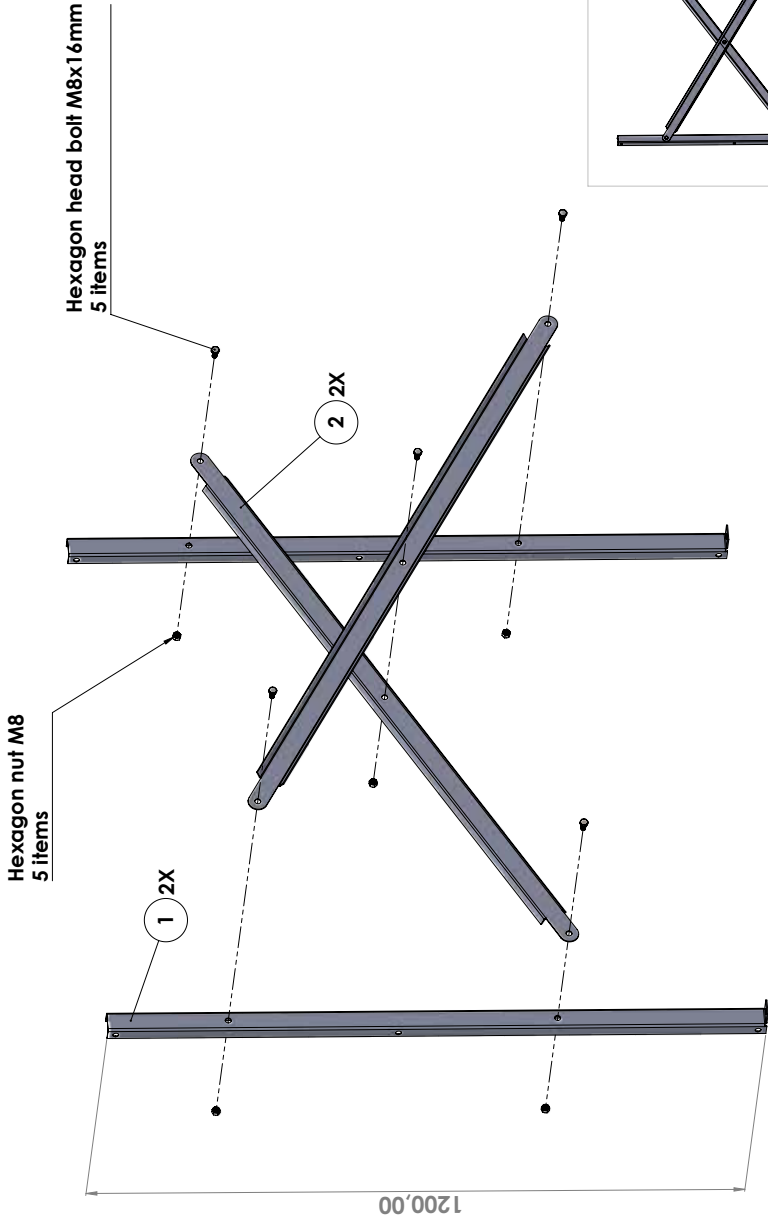

Assembly step 2

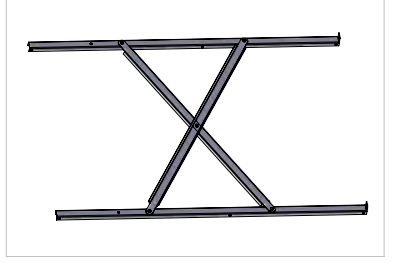
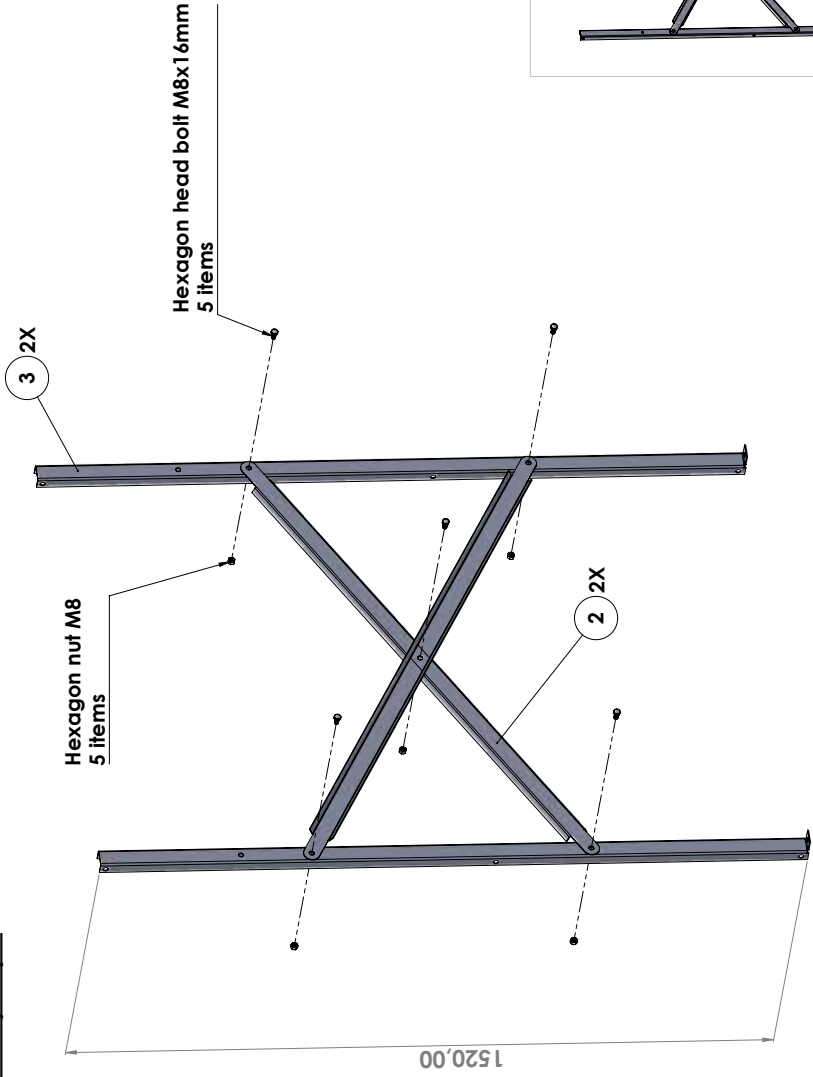

Assembly step 3

Hexagon nut M8
8 items

Hexagon head bolt M8x16mm

Hexagon head bolt M8x60mm
2 items

Hexagon head bolt M8x16mm
6 items

4 2X

5 2X

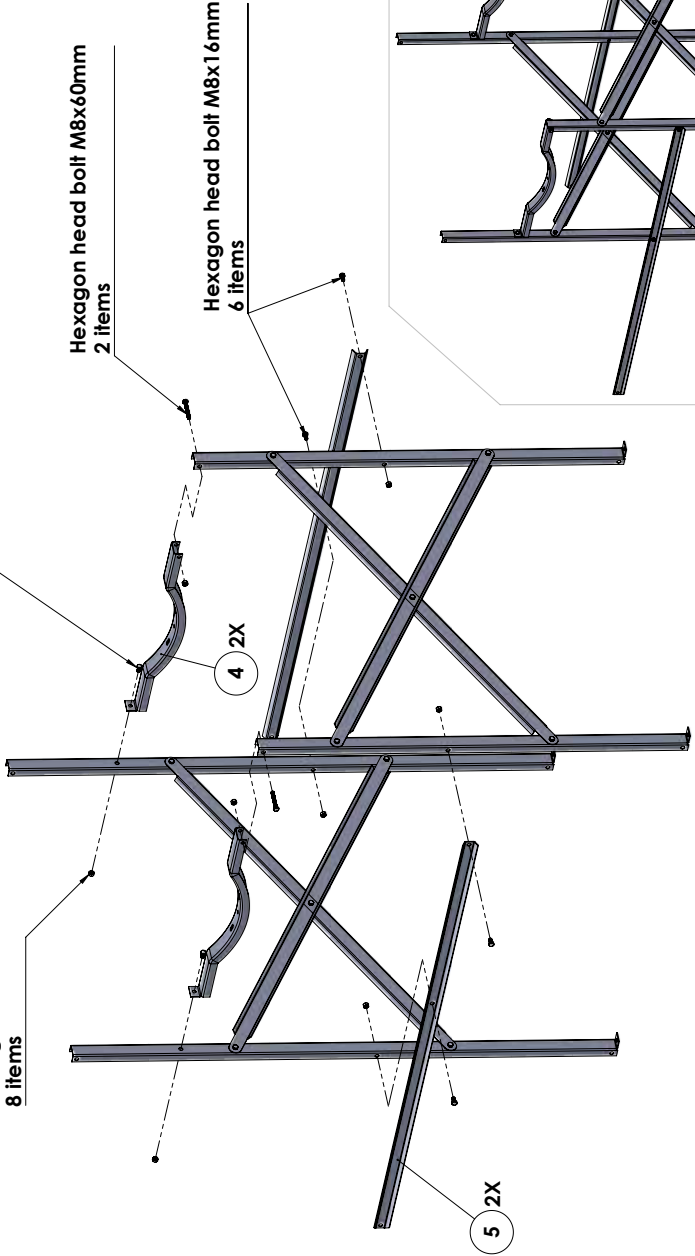
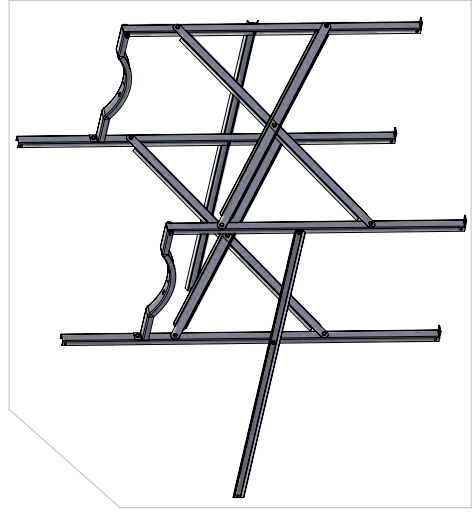

Assembly step 4

Hexagon nut M8

6 2X

Hexagon nut M8
4 items

Hexagon head bolt M8x60mm
2 items

Hexagon head bolt M8x16mm
2 items

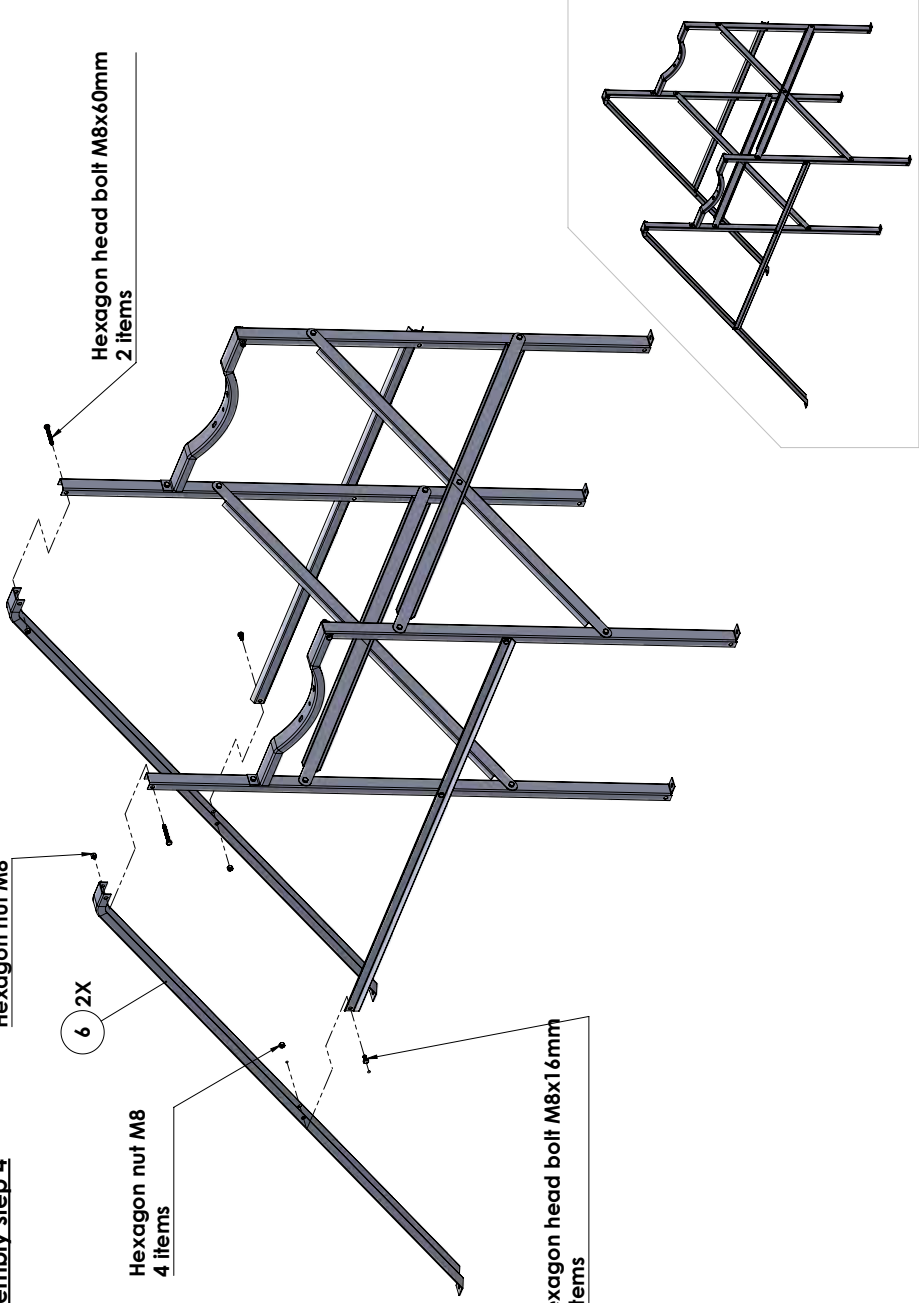

Assembly step 5

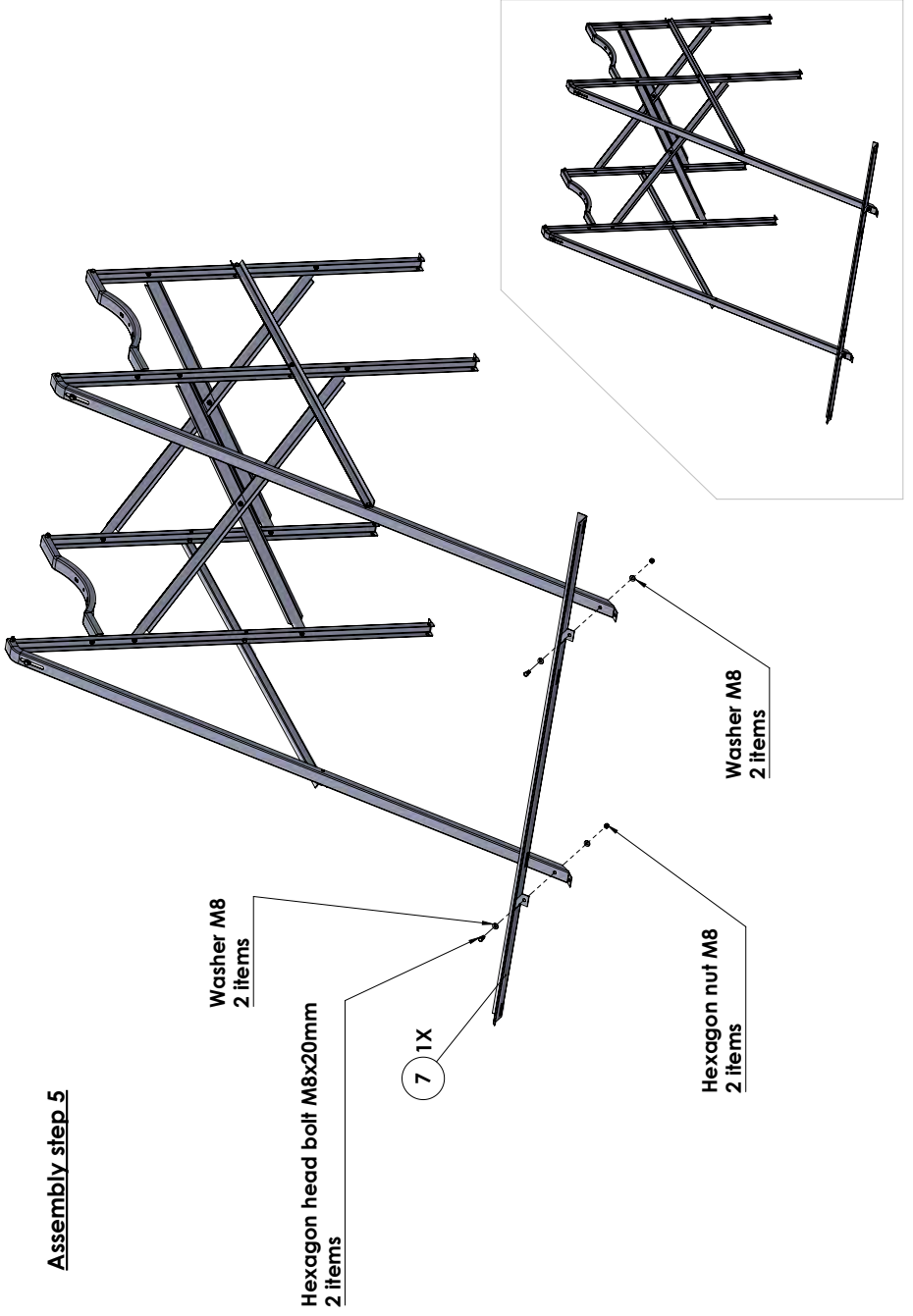

Assembly step 6

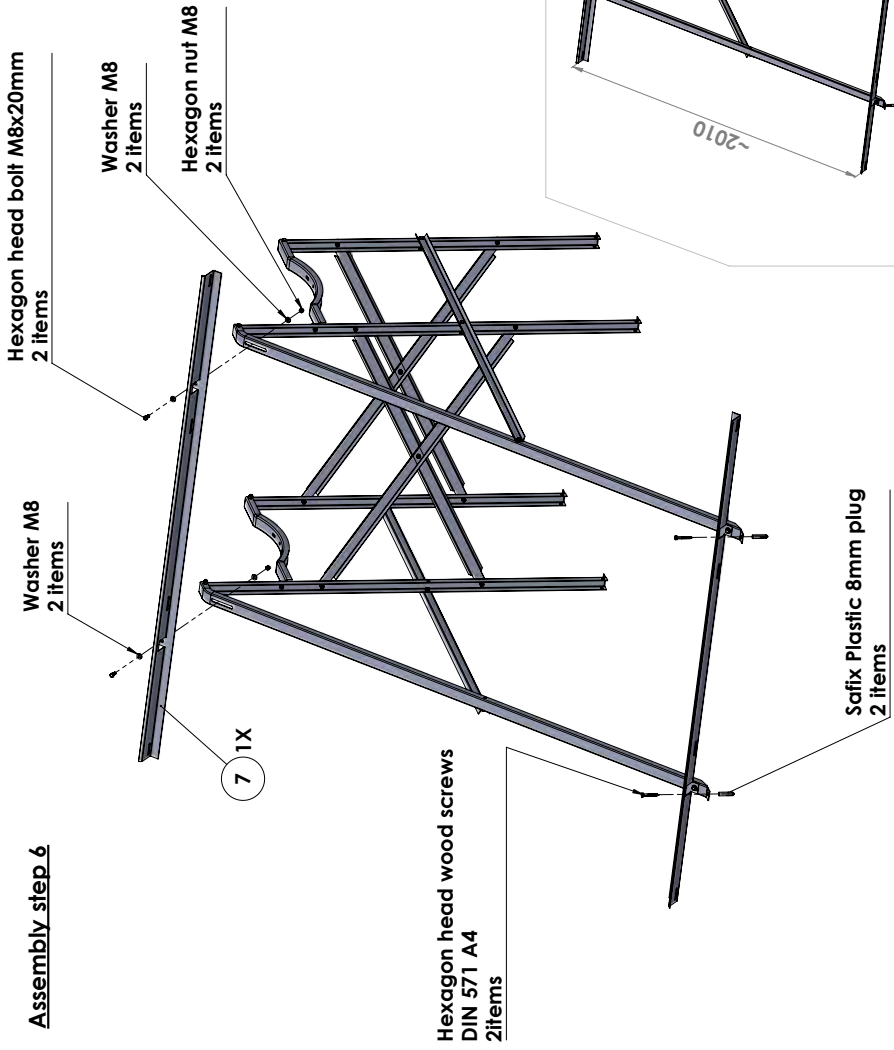

Assembly step 7

Hexagon head bolt M8x16mm
4 items

Washer M8
4 items

8 1X

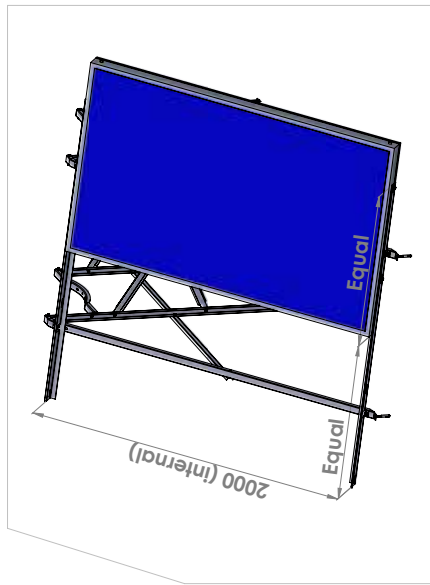
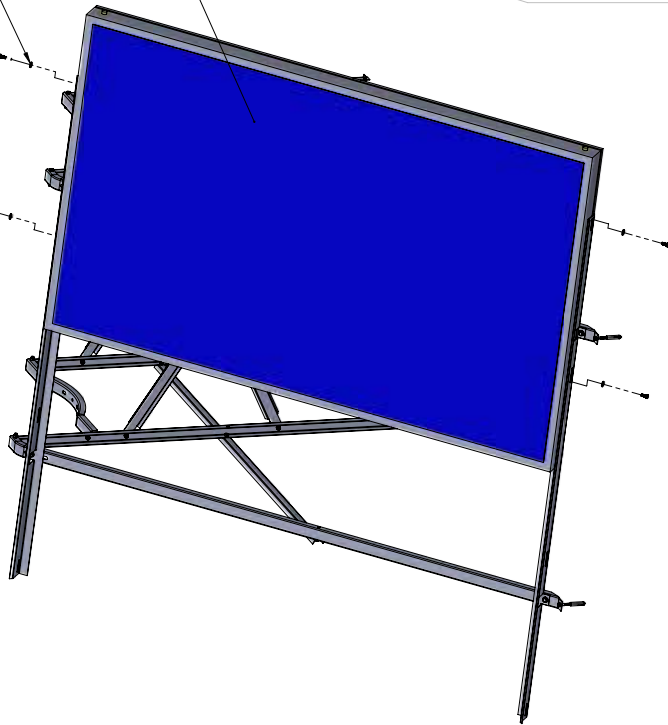

Assembly step 8

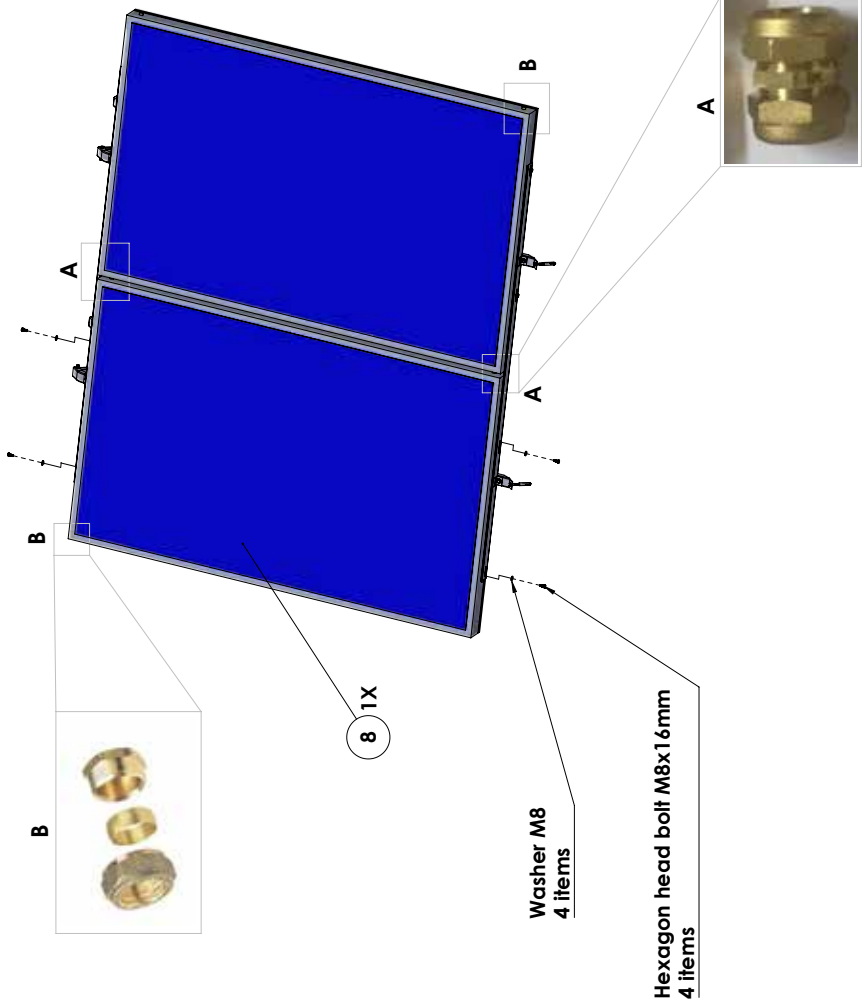

Assembly step 9

9 1X

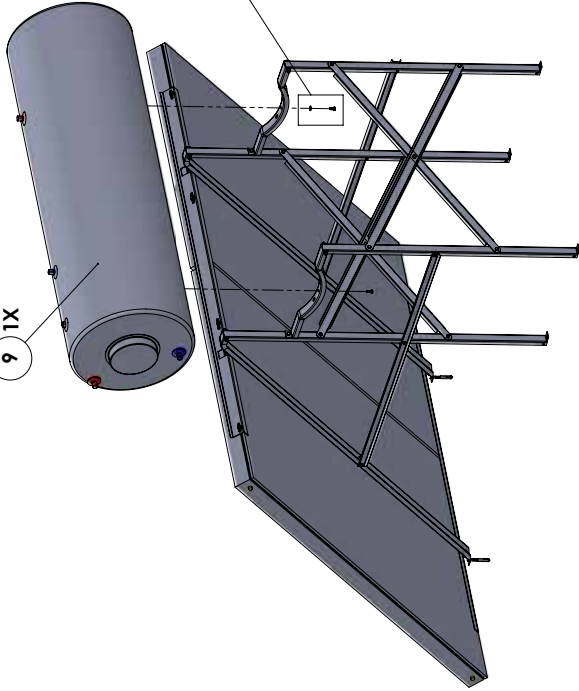

Washer M8
2 items

Hexagon head bolt M8x20mm
2 items

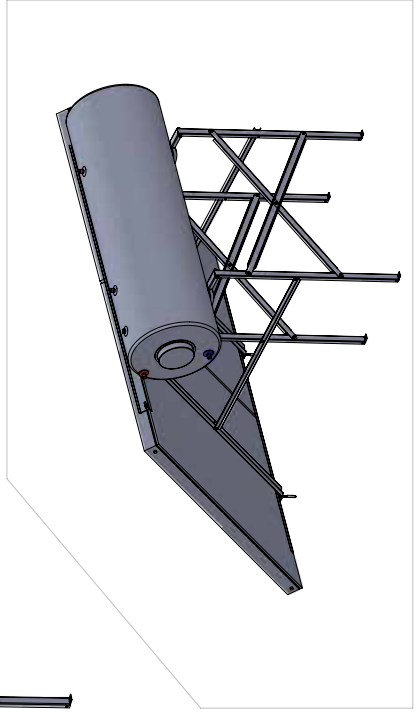

Assembly step 10

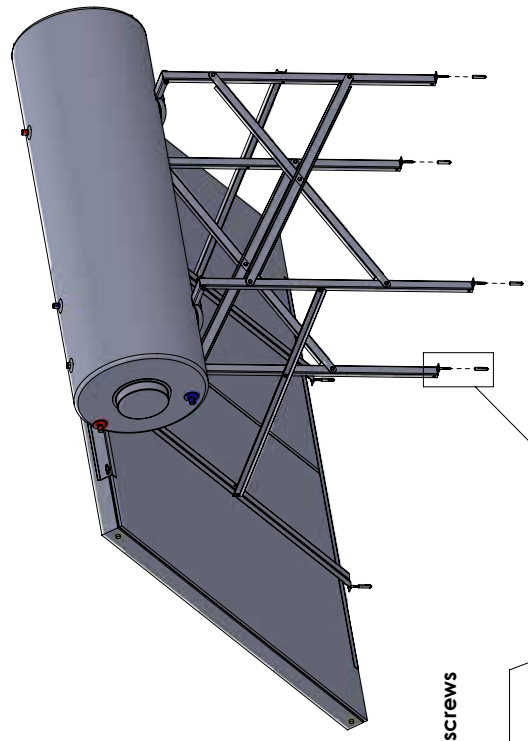

**Hexagon head wood screws
DIN 571 A4
4 items**

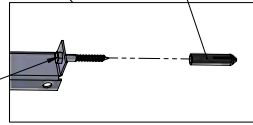

**Safix Plastic 8mm plug
4 items**

Assembly step 11

Hot water outlet
G3/4



Optional equipment (not included)

If continuous high temperatures are expected, due either to oversizing of collectors for the actual location or location's climatic data, on the primary (solar) circuit, the use of thermostatic relief valve is mandatory (not included in the SWH set). Guarantee is not valid if not installed.

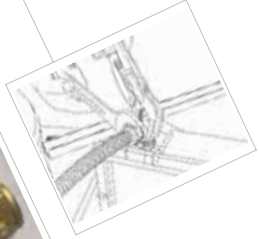
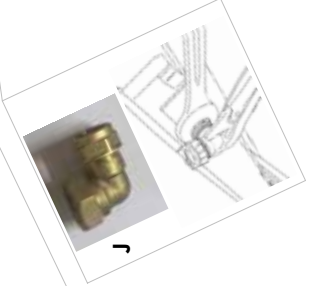

Assembly step 12

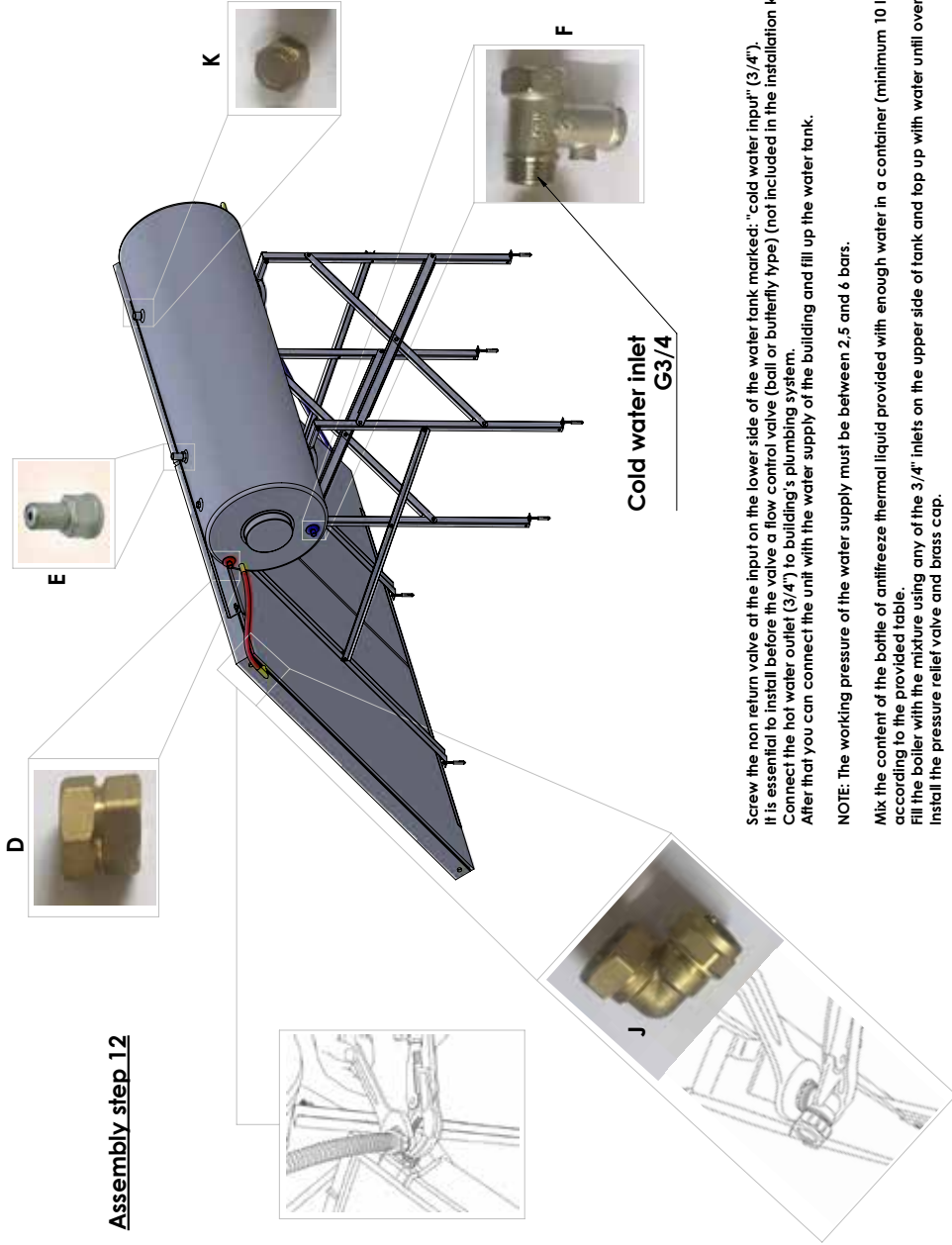

Screw the non return valve at the input on the lower side of the water tank marked: "cold water input" (3/4"). It is essential to install before the valve a flow control valve (ball or butterfly type) (not included in the installation kit). Connect the hot water outlet (3/4") to building's plumbing system.

After that you can connect the unit with the water supply of the building and fill up the water tank.

NOTE: The working pressure of the water supply must be between 2,5 and 6 bars.

Mix the content of the bottle of antifreeze thermal liquid provided with enough water in a container (minimum 10 litres of water) according to the provided table.

Fill the boiler with the mixture using any of the 3/4" inlets on the upper side of tank and top up with water until overflows. Install the pressure relief valve and brass cap.

4. table of proportion and antifreeze protection

% vol.	Frost protection [°C]
25	-10 °C
30	-14 °C
35	-17 °C
40	-21 °C
45	-26 °C
50	-32 °C
55	-40 °C

5. THERMOSIPHONIC SYSTEM Instructions and maintenance.

General instructions and maintenance

- The system will reach optimum performance two days after installation.
- We recommend to inspect the glass cover of the collectors periodically ,clean them in case there is dust or snow or anything else that might interfere the solar rays, see any cracks on the surface and replace it as soon as possible if you see any possible damage.
- Check the antifreeze liquid of the circuit at least once per year and add the necessary quantity to fill the system.
- Check at least once per year the all valves ,check if any bolts and nuts are well screwed and generally check the stability of the support frame.
- If you decide to leave the house for a long period ,cover the collectors ,it is essential for the well being of the circuit.
- Check periodically for any leaks ,any bended tubes ,air bubbles trapped in the system ,check if all tube connections are in the proper exits and inlets.

Electrical resistance

- Check for obvious damage of the electrical element with thermostat.
- Check the wiring connection of the resistance and the thermostat.
- Check if the thermostat is placed in the proper temperature ,temperature should not exceed 75° C. The factory adjustment is 65° C.
- Check if main supply reaches the element.
- Always turn the power off before you start repairing the electrical parts of the system.

Magnesium bar (anode)

- Before checking or replacing the anode turn the power off.
- Empty the water from the tank.
- Unscrew the resistance tap.
- Remove the thermostat from the element.
- Unscrew the flange carefully.
- Unscrew the anode ,check or replace the bar back in position.
- Place back the flange and follow the procedure vice versa.
- Refill the tank.
- Switch the power back on.

Lightning protection

The collectors should always be connected (the metallic parts) through a copper conductor 16mm with the lightning conductor system, if there is any ,if not the collectors should be connected with any conductor system using the same copper conductor from the collectors.

The conductor shouldn't go through the inner space of the house and it should be installed by a certified electrician.

Collectors are installed on top of a metallic support base and the installer should check if the collector is attached with a secure manner, checking all the bolts and screws if they are well placed.

Always call a certified installer to do the proper maintenance of the system, in case there is an electrical issue please call a certified electrician.

MANUFACTURED BY:

THERMIC LTD

Loutsas & Mesologgiou str.

19600 MANDRA Industrial zone, ATHENS, GREECE.

TEL: +30 210 5555523 FAX: +30 210 5555668

www.thermicsol.com

MANUFACTURED BY:

THERMIC LTD

Loutsas & Mesologgiou str.
19600 MANDRA Industrial zone, ATHENS, GREECE.

TEL: +30 210 555523 FAX: +30 210 5555668

www.thermicsol.com